

TIMBA STOOL

TEAM PLAYER AND TEAM WORKER

The new swivelling stool from Bene gets things moving in the office! The TIMBA Stool blends in easily and seamlessly with the informal collaboration and team zones of contemporary office concepts. With its deliberately non-formal character, the TIMBA Stool is a clear counterpoint to the strictness of classical

seating furniture, and thus helps to create an atmosphere in which the process of communication and creativity can unfold. As an ideal opportunity for teamwork and informal exchange, the TIMBA Stool is open to the various forms of office activities.

Design: Pearson Lloyd



bene

INSPIRING OFFICES. SINCE 1790.

PRODUCT DESCRIPTION

The TIMBA Stool is available in sitting height or as a TIMBA Stool high in standing height.

- ❶ **Seat:** Seat shell made of fibreglass-reinforced plastic in off-white or dark grey, with upholstery in fabric or leather (L1 black).
- ❷ **Frame:** Legs made of solid oak, natural varnish or stained graphite. With duo glides (plastic glides or felt glides each on one side).
- ❸ **Backrest:** Optional. Colour always like the seat shell.
- ❹ **Foot ring:** Made of fibreglass-reinforced plastic in dark grey.

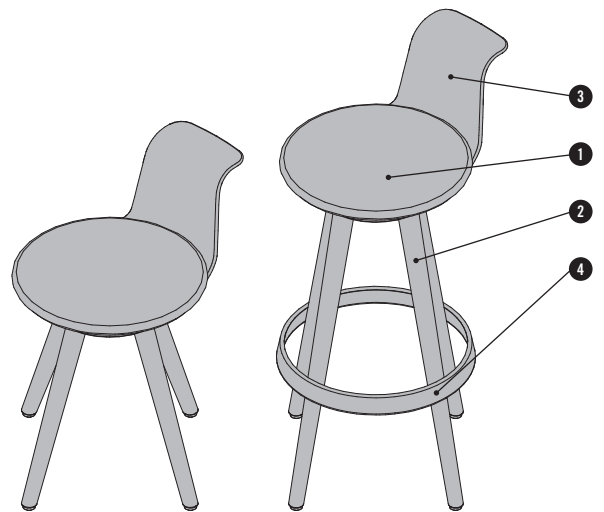

OVERVIEW AND DIMENSIONS

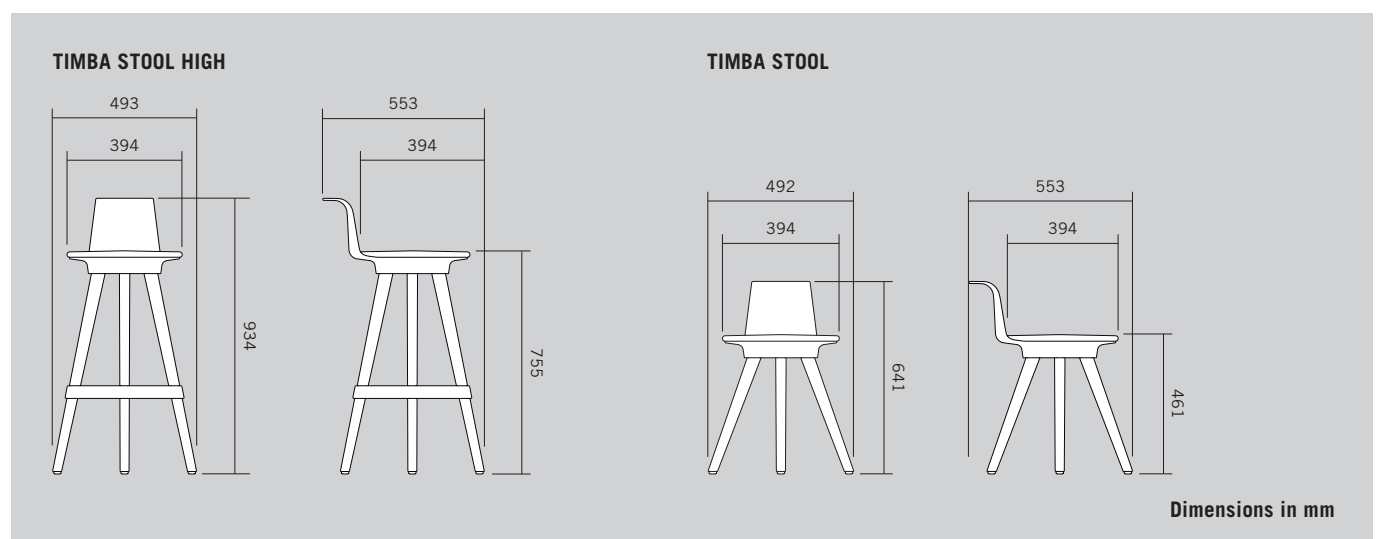

COLOURS & MATERIALS

SOLID OAK



HC nature

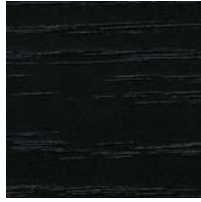

HD graphite

SOLID-COLOURED PLASTIC

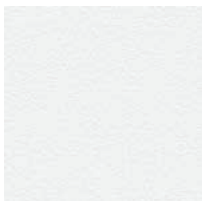

GW off-white

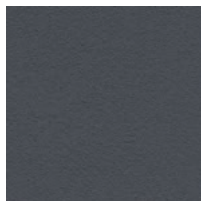

GB dark grey

FABRIC AND LEATHER



Various fabric collections are available for the cover: Era, Urban Plus, Xtreme Plus, Rondo, Step, Step Melange, Remix, Europost, Mainline Flax, Fox, Fiord, Steelcut, Stamskin Top, Hallingdal, Steelcut Trio, Divina Melange, Divina MD.
Various leather collections: Entrée (Black).

More information about the specific fabric and leather collections is available at www.bene.com.

SUSTAINABILITY

From the specifications stage through to series production, ecological requirements are always an important factor in the development process. This includes selecting environmentally compatible materials, such as CoC-certified timbers from sustainably managed forests, using recycled materials and increasing the use of renewable raw materials. In order to guarantee a high recyclability standard for our products, we avoid composites as much as possible and develop furniture that allows for disassembly.

Labelling of materials, their ability to be repaired, and a long service life for the components used, are other important requirements for product design. But the ability to disassemble and recycle the products at the end of their lives are also important criteria.

SUSTAINABLE RAW-MATERIALS

At Bene, the following materials are used as a matter of course:

- chipboards low in formaldehyde
- glues low in formaldehyde
- water-based varnish systems
- recyclable materials
- materials with a high recycling share
- PVC-free synthetics

Bene guarantees products free from:

- CMR substances
- halogenated solvents in synthetics
- chlorinated hydrocarbons
- heavy metal pigments
- materials with azo pigments
- Coatings with biocidal effects (such as wood preservatives, pesticides).

CONTRIBUTION TO BUILDING CERTIFICATIONS

In the context of ecological building certification, design systems such as furniture and dividing walls help to achieve a good result and a higher score.

Bene's products make a contribution towards the LEED, WELL Building Standard, DGNB, BREEAM, etc. certifications. Criteria include, for example, environmental product declarations, indoor air quality, acoustics and convertibility.

TIMBA STOOL

Example configuration

- Timba Stool high, with backrest
- synthetic fibres
- total weight 7,25 kg

Environmental key figures

- 89,2 % sortable by type
- 80,9 % recyclable
- 45,8 % of contents are renewable raw materials
- 0,7 % recycled production materials

Materials

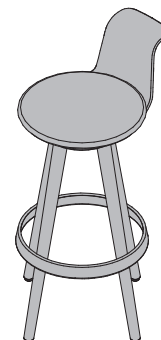
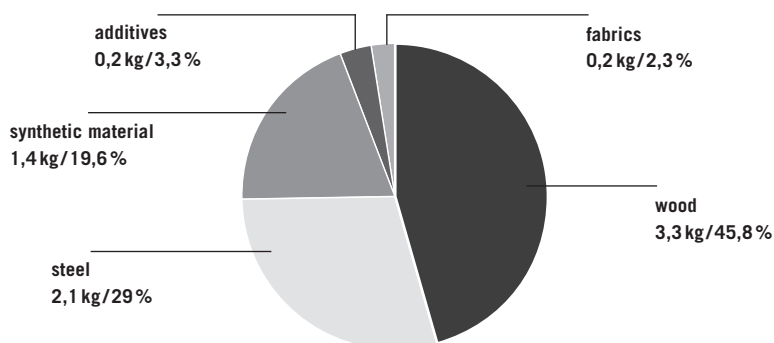

On request, Environmental Product Declarations (EPD, LCA) – at Bene we call them Life Cycle Data Sheets – can be provided for all standard product configurations.

A list of product-specific certificates and design awards can be found on the Bene product website:

<https://bene.com/en/office-furniture-concepts/office-furniture/timba-stool-by-pearsonlloyd/>

Environment-related information about Bene: <https://bene.com/en/sustainability-report-2021/>

